

# AGRICULTURAL EXPERIMENT STATION

COÖPERATING WITH

ENGINEERING EXPERIMENT STATION

KANSAS STATE COLLEGE

MANHATTAN, KANSAS

---

## EQUIPMENT FOR SWINE PRODUCTION



## TABLE OF CONTENTS

---

	PAGE
INTRODUCTION .....	5
IMPORTANT FEATURES OF HOG-HOUSE LOCATION.....	5
IMPORTANT FEATURES OF HOG-HOUSE CONSTRUCTION.....	8
TYPES OF HOG HOUSES.....	11
Advantages of the community type of hog house.....	11
Advantages of the movable, individual house.....	15
Combined use of community and individual houses.....	18
DETAILS OF THE INDIVIDUAL HOUSE.....	19
DETAILS OF THE COMMUNITY HOUSE.....	20
Floor and foundation .....	20
Doors .....	21
Windows .....	22
Pens .....	22
Pen gates and partitions.....	22
Fenders .....	22
Troughs .....	24
EQUIPMENT FOR FEEDING.....	24
Self-feeders .....	24
Feeding racks .....	28
Feeding floors .....	29
Feeding troughs .....	31
Waterers .....	33
EQUIPMENT FOR CARE AND MANAGEMENT.....	36
Pig creeps .....	36
Breeding and holding crate.....	37
Castrating trough .....	38
Loading chute .....	38
Shipping crate .....	40
SUNSHINE TABLE FOR KANSAS.....	42
APPENDIX .....	44
List of available plans .....	44

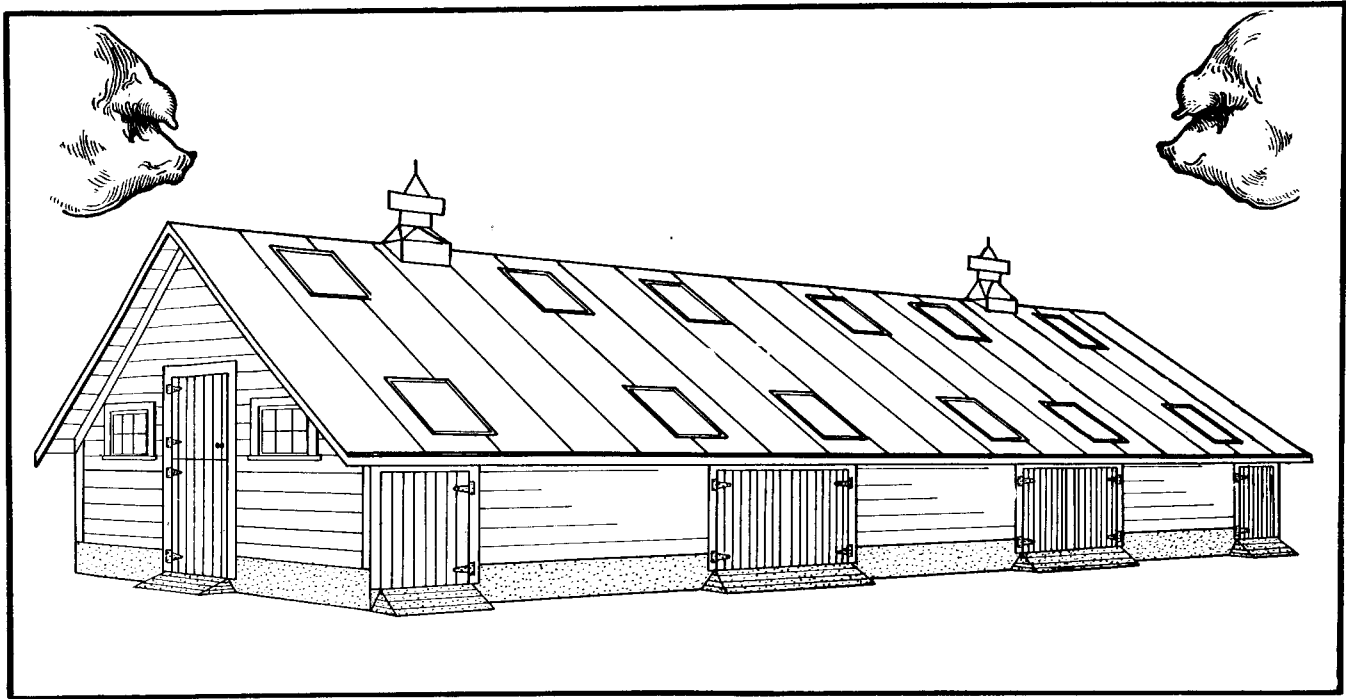

FIG. 1.—Farrowing house: The materials for a 12-pen house of this type can be purchased for approximately \$50 per pen. (Floor plan is shown in figure 2.)

# EQUIPMENT FOR SWINE PRODUCTION<sup>1</sup>

B. M. ANDERSON<sup>2</sup> and V. R. HILLMAN<sup>3</sup>

## INTRODUCTION

It is the purpose of this bulletin to enumerate a number of the essential and desirable features of swine-production equipment and to describe and illustrate a variety of buildings and equipment that have proved practical on Kansas farms and elsewhere. It is not expected that all the suggestions are equally applicable to every individual farmer, but that each may find some hints whereby he may be able to increase the efficiency of his pork-production plant.

## IMPORTANT FEATURES OF HOG-HOUSE LOCATION

The following fundamental requirements affecting the location of hog houses have general application.

1. **Sufficient Drainage.**—Rolling ground is unquestionably best for drainage, since low, level land is more likely to be damp and unsuited for swine. Sandy soils furnish a desirable base because water drains through them readily. Heavy clay gumbo or other water-holding soils are to be avoided. Drain tile may often be used to advantage in soils not having good natural drainage.

2. **Sunny Exposure.**—An open, well-sunned space, where direct sunlight will strike the house throughout the day, should be selected. It is best to avoid the heavy shade of trees and other buildings.

3. **Southern Slope.**—A southern slope is preferable because of its sunny exposure, which means much to the successful raising of suckling pigs. Warmth, dryness, and natural air drainage, all conducive to the best results with pigs, are promoted by the southern slope.

4. **Protective Windbreaks.**—The extremely cold winds in Kansas come from the northwest. The most efficient site, therefore, is southeast of a good, substantial windbreak of hills, trees, buildings, fences, or their combination.

5. **Nearness to Pasture and Summer Shade.**—Convenient pasture and summer shade are both indispensable for economical pork production.

---

1. Contribution No. 84 from the Department of Animal Husbandry.

2. B. M. Anderson was formerly a member of the staff in the Department of Animal Husbandry in the Agricultural Experiment Station (resigned).

3. V. R. Hillman was formerly assistant agricultural engineer in the Engineering Experiment Station (resigned).

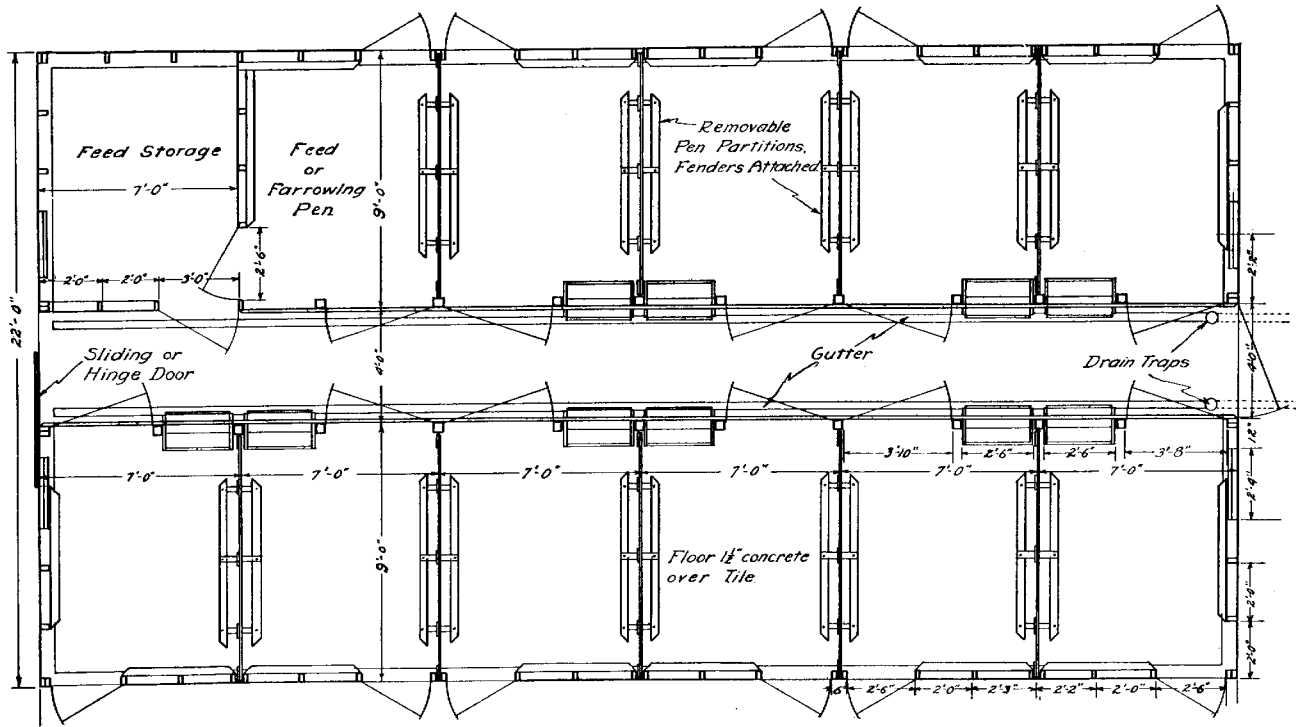

FIG. 2.—Floor plan of 12-pen farrowing house. (Outside view and sectional views are shown in figures 1 and 3. This house can be enlarged in units of four pens.)

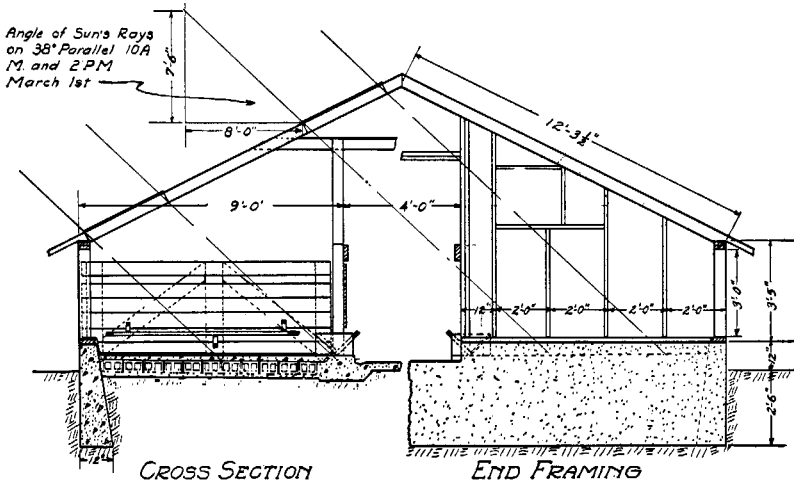

FIG. 3.—Section through pen, and end framing of farrowing house.

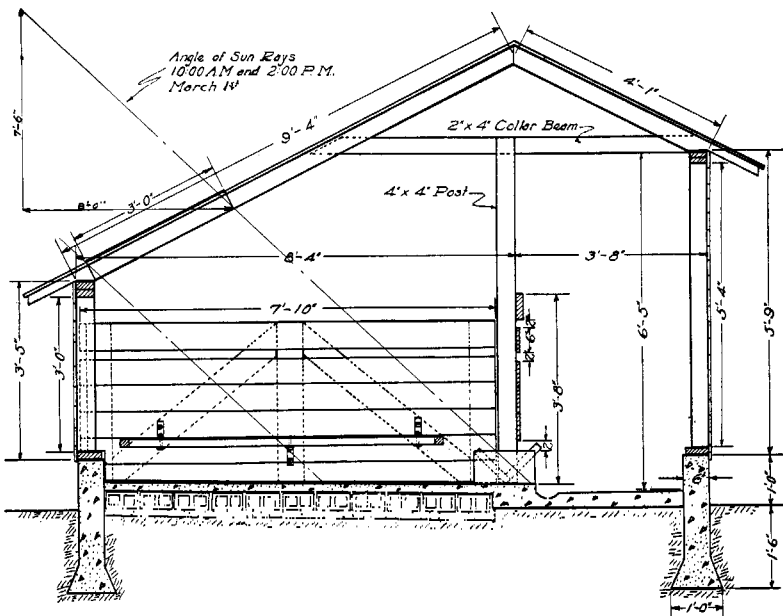

FIG. 4.—Section through a single-row, combination-roof farrowing house.

**6. Suitable Elevation.**—The high situation is likely to be bleak, cold, and inconvenient; the low, damp and unhealthy. A medium elevation, neither too high nor too low, is desirable.

**7. Prevention of Odors Reaching Dwelling.**—Inasmuch as somewhat unpleasant odors may emanate from swine shelters, the piggery should be a reasonable distance from the farmhouse, and preferably not in the direction whence the prevailing winds come.

**8. Least Possible Risk from Disease Infection.**—Locations close to public highways, railroads, and open waterways, unless free from possible infection, are to be avoided. The neighbor's herd may carry infection and this source of danger should be considered. Reasonable isolation of the swine herd is advantageous.

**9. Economy of Labor and Time in Management.**—To save time and energy, feed, water, and bedding should be near at hand. The location of the hog house should fit in with the general scheme for doing farm chores efficiently.

#### IMPORTANT FEATURES OF HOG-HOUSE CONSTRUCTION

Hog houses, although built in many types, should have in common the characteristics discussed below. (Figs. 1 to 10.)

**1. Warmth.**—The hog house should be sufficiently warm that the pigs never will have to pile up to keep warm. Hogs lack the natural coat of other farm animals and huddle up when cold. This often results in pneumonia or suffocation.

**2. Ventilation.**—Fresh air is equal in importance to feed and drink. Ventilating and keeping the house warm at the same time calls for correct construction and accurate knowledge as to requirements. Ventilation in the hog house is as fundamentally necessary as warmth.

**3. Sunlight.**—Direct sunlight promotes the health and vigor of farm animals. During the late winter and early spring months in the North Central states the sun shines only about one-half the time, and the animals seek the sunny spots in winter, even climbing up on manure piles, or other elevations, to catch the first rays of the sun. Direct sunshine at some time during the day should strike every part of the interior of the well-designed hog house, especially the floors of the pens during the farrowing months of February, March and April.

**4. Dryness.**—The difficulty in keeping makeshift quarters dry has been the cause of many runts and dead pigs. A dry, well-

drained floor and weatherproof and waterproof roof and walls are very necessary.

**5. Sanitation.**— The hog is one of the cleanest of our domestic animals—when given the opportunity. He will keep his bed scrupulously clean if given half a chance. The hog always breathes, eats, and drinks close to the ground. The well-planned hog house, therefore, must provide for quick, easy, and frequent cleaning. Smooth walls and floors without crevices are necessary, and these make possible more thorough disinfection.

**6. Safety and Comfort.**— Comfortable hogs housed in safe quarters are the biggest money makers. Unless careful attention is given to every detail there will be many unsuspected leaks in the profits. High doorsills frequently cause abortion. Rough, uneven floors cause much discomfort, and possible injury to the pregnant sow. Slippery floors contribute to nervousness and accidents. Pig-saving fenders are necessary in the farrowing pens.

**7. Convenience.**— While providing for the health and comfort of the hogs, it is equally important that the interior arrangement of the hog house be such that the attendant can quickly, easily, and efficiently perform all the necessary work. Attention should be given to convenient alleyways, doors, and windows; abundant and convenient water supply; handy storage bins; easily regulated ventilators; litter, feed, and swill carriers; sanitary and economical feeding troughs; adequate drainage; accessible and properly protected feeding floors; and artificial heat, (when required) for warming swill and heating the house. These and other step- and back-saving devices go a long way toward making the attendant's labor more productive and increasing his interest and joy in the work.

**8. Sufficient Size to Shelter Advantageously.**— The size of the house should obviously be in accordance with the greatest number and size of hogs that would be housed at any time during the winter. The added ease with which hogs can be cared for in a well-planned community hog house will make possible the keeping of a bigger herd than before. It is well to build a little larger than needed for immediate requirements, and provisions for future extensions should not be overlooked.

**9. Durability.**— The house that is so built that it will stand the weathering of many years and the strain of everyday use is most



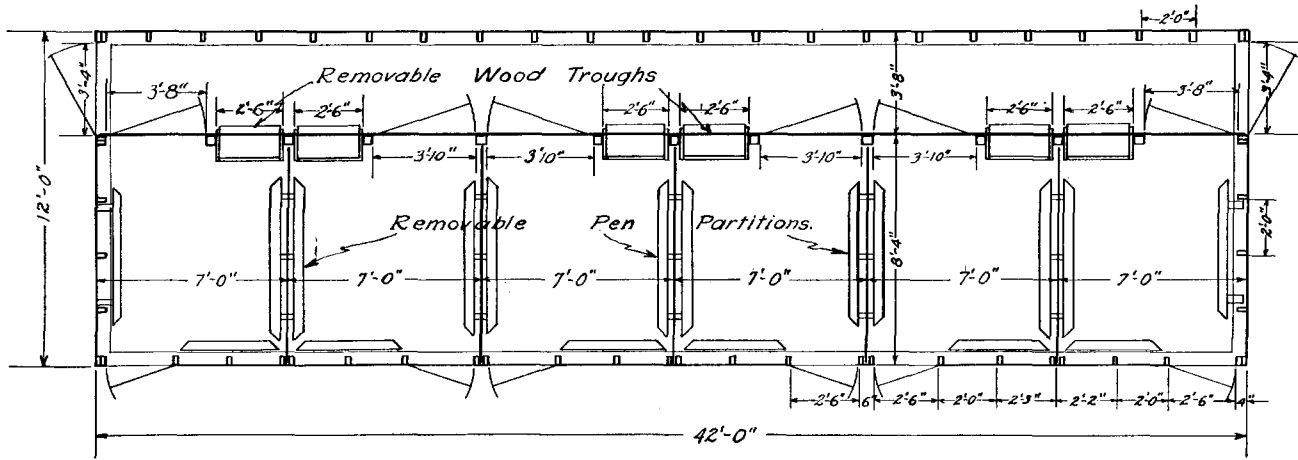

FIG. 5.—Floor plan of single-row farrowing house. The feed alley is along the north wall, giving all pens south exposure.

to be desired and the cheapest in the long run. When a man puts up a permanent-type hog house, he wants to be through with tinkering and patching.

**10. Reasonably Low First Cost.**—The cost should be in keeping with the service rendered.

**11. Pleasing Appearance.**—After the hog house is considered satisfactory in every service requirement, it should also harmonize with the general surroundings; it should be neat in architectural design and practical in construction.

#### TYPES OF HOG HOUSES

Piggeries are of two general types, the large centralized community or stationary house, and the small individual or movable house.

The centralized house generally contains a number of pens which may or may not have removable partitions. It is a comparatively large, elaborate, and durable structure. Undoubtedly there is much of merit in the centralized system of swine housing and management.

The individual house has but one pen, hence the name. This house is usually built to accommodate one sow and her litter. It is small, light of weight, simply constructed, and durable.

The combined use of the two types of hog houses—the centralized supplemented by the individual—finds favor in the practice of many of the most successful swine raisers. Each type of house has its own peculiar advantages and disadvantages, whereas the two together so counterbalance in their merits and demerits as to make a very efficient and practical system of swine housing. Experience and observation lead the writers to encourage the use of the combination system.

Figures 5 and 6 show a farrowing house of moderate cost, but good construction throughout. It has but one row of pens and these all have a south exposure, thus providing warmer outside pig runs for early farrowed litters than is possible with north-exposure pens. The roof windows admit plenty of sunlight where it is wanted, and the alleyway, being along the north wall, gives the farrowing pens the warmest part of the building.

#### ADVANTAGES OF THE COMMUNITY TYPE OF HOG HOUSE

I. Time and labor are saved. Not so much time and energy are required to give the stock the necessary care.

1. Facilities for warming, feeding, watering, dipping, ringing, castrating, marking, breeding, weighing, and administering (medicines) are more convenient because they are under one roof.

2. The sunning of the quarters, especially during the season of early litters, is done more quickly, inasmuch as a number of houses do not have to be visited to see that the windows are not covered with snow or sleet, or otherwise obstructed.

3. The artificial exercising of young pigs that are subject to thumps and kindred troubles is easily done in the community hog-house alley, a number of litters being driven at the same time. This is in marked contrast to the distributed effort necessary in the movable, isolated house system.

4. Ventilation is more readily controlled because only two or three ventilators within close range need to be visited.

5. Promising pigs are more easily and quickly exhibited to prospective buyers.

6. With all sows under one cover during the farrowing season, they are more easily cared for.

7. There is no moving of a number of houses to new locations.

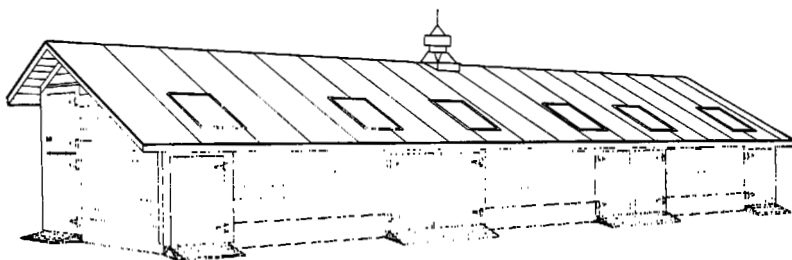

FIG. 6.—Perspective view of the house shown in figures 4 and 5.

II. It is more durable. The community house permits the use of more permanent and fire-resisting building materials. Its floor is permanent and practically immovable, built in to stay. It has a solid masonry foundation, and the walls also may be made of masonry. These features are impossible in the movable types. Heavy winds, soaking rains, driving hail, deep snows, and extreme temperatures are more easily withstood in a structure that is tighter and better built generally.

Repairs and maintenance are more easily kept up in one big house on a permanent foundation and within relatively easy reach (near the other farmstead buildings) than in a number of small and usually widely scattered houses with somewhat unstable footings. Those who use the community hog house appreciate its convenience.

III Lighting from direct and diffused sunlight is more conveniently arranged. Direct sunshine is more practically secured in the large house because of the advantages of greater height and better-arranged roof areas.

IV. The ventilation may be more systematic. The ventilators are easily adjustable. The principles of successful ventilation are more easily introduced in the larger type because there is greater opportunity for ducts and flues. The overhead space is larger in proportion to the occupant's live weight, thus requiring less frequent changing of air.

V. Close attention to the herd is possible. Vigilance is of prime importance at crucial times, such as at farrowing; with sows under one roof this is possible and practical. It is impossible to attend closely a number of farrowing sows scattered in widely separated houses.

VI. The herdsman experiences a minimum of exposure. In the community house he does his work largely indoors, and is independent to a considerable extent of weather conditions, since he is under water-tight cover and surrounded by warm, protective walls. During the busy farrowing season the caretaker may sleep in the warming or feed room, near the stove, and thus be at hand for emergencies, without the undue exposure experienced in frequent nightly visits to a number of outlying individual houses.

VII. Feed storage, water supply, and general-purpose rooms are very practical. The great convenience of indoor feed bins and water taps is clear. A mixing room equipped with soaking, heating, and cooking devices near to the feeding alley is easily possible. An office and sleeping room appeals to many. The scales for weighing may be placed in the workroom or in the alley, and likewise shelves may be built to hold all of the small equipment and necessary medicines. The hurdles, troughs, breeding crates, ringing chutes, self-feeders, automatic waterers, and other devices may be stored with satisfaction. Storage, water, and general conveniences requiring sheltered space are impractical in small movable houses.

VIII. Sanitation may be encouraged. Substantial, smooth, vermin-proof masonry construction is possible in the permanently built community house. With smooth floors, the cleaning of the house is greatly facilitated and encouraged. The inaccessible cracks that harbor lice, mange, and other parasites may thus be eliminated with all their attendant evils. The open-cracked wooden floor and walls in the movable and sometimes in the temporary community type are objectionable. Sanitary disposal of liquid waste through a drainage system commends itself; this is made possible by the permanent location and justifies the necessary expense of a permanent sewerage system. Manurial litter is removed to the fields more

easily, hence it is more likely to be done. The litter carrier, which may be easily installed, also encourages the removal of wastes. Then, too, the greater accessibility of the large house encourages more frequent attention to sanitation. With a concrete approach to the entrance door of the house there is less probability of mud and filth being carried into the nest than where the doors open directly onto the ground.

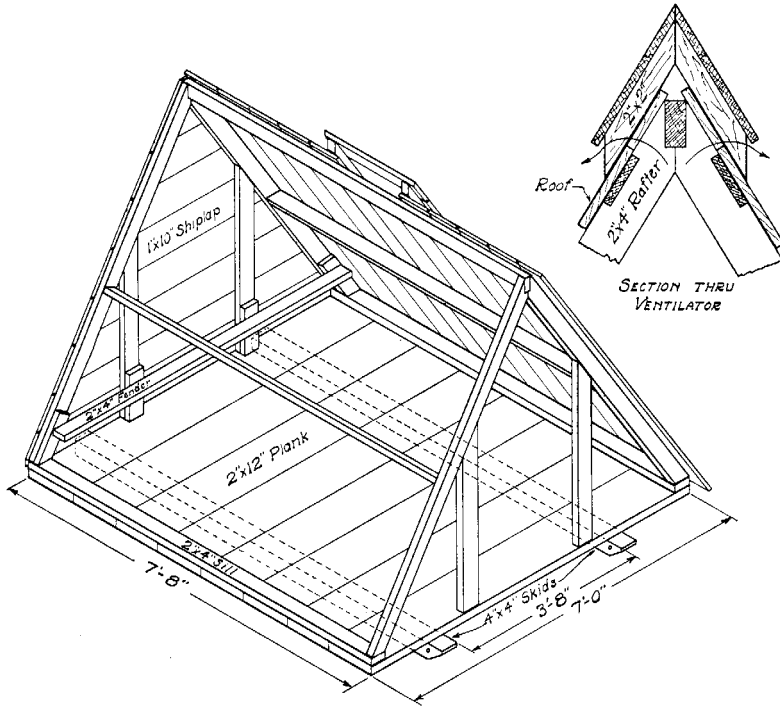

FIG. 7.—Kansas "A"-shape individual house.

IX. Heating the community house is comparatively easy. Uniform heating is convenient, inasmuch as a single stove will be sufficient in houses of ordinary size. The troublesome attention necessary when many lanterns or small heaters, as well as ventilators, are to be looked after in a number of outlying individual houses is self-evident. The permanent house, properly built, is warmer in that the wind does not penetrate under the floor and thus induce drafts. Of course, with the movable type the floors may be banked to exclude wind, but banking is more easily done to one house than to many.

X. The huddling and piling up which is oftentimes a bugbear when several small movable houses are used together is largely avoided in the warm, permanent house of large capacity.

XI. Fire and other risks may be minimized. Concrete or clay-block construction of floor and walls, when used with such material as asbestos roofing, reduce fire hazards and also depreciation and maintenance charges. The first cost of such construction, however, may make the strictly fireproof structure impracticable. The efficient small house must be comparatively low in first cost, which may require the use of inflammable materials. The metal hog house is not recommended.

XII. Grouped swine become better acquainted. Swine kept in a community house with open partitions separating them learn to know each other, and thus when they are turned together there is less quarreling. The opposite is true with isolated swine, especially sows; they often suffer severe injuries, loss of flesh, and sometimes death in the preliminary fight which seems to be a necessary prelude to their becoming acquainted.

XIII. It makes possible adjustable pens. The removable partitions may be so manipulated as to throw the entire house into one large pen, or different combinations of the units may be made, such as making two, three, or four pens into one.

XIV. The advertising value is greater. The impressiveness of the large, permanent, centralized community house is of value. A large, roomy, well-lighted house, equipped with durable, up-to-date and convenient fixtures, appeals to the average buyer more forcefully than the smaller house, no matter how ingeniously built.

#### **ADVANTAGES OF THE MOVABLE INDIVIDUAL HOUSE**

I. The location may be changed when desired. The movable feature is important. The individual house (figs. 7, 8 and 9) may be situated as demands vary, so as to: (1) Provide easily accessible pasture. (2) Furnish protection from the elements and disease. (3) Be convenient to other buildings, water, and shade. (4) Economize feeding when providing individual pasture for sows and litters, or other hogs; thus dispensing with fenced lanes or runways. (5) Encourage exercise, especially for pregnant sows and growing pigs. (6) Be near common feeding floor. (7) Supply shelter for hogs following cattle, other than that in general sheds. (8) Afford housing for the sow that unexpectedly farrows in pasture or field. (9) Render the greatest possible service throughout the year.

**II** Isolation may be secured quickly and conveniently. The separation of swine from others of their kind is of special value at times because: (1) Quietness at farrowing time is assured. (2) Uniform development of the suckling pigs is encouraged. Disturbances such as the troublesome squealing of pigs from other litters and the clamoring of disgruntled sows are eliminated. Robbing, being restricted within the litter, is reduced to a minimum. The isolation of litters in secluded pastures is an ideal method for the promotion of even development. (3) Danger from loss is minimized. Spread of disease through the herd is retarded. Huddling, piling up, fighting and other unfavorable results of crowding are largely avoided. (4) Developing boars may be segregated. The prevention of accidental breeding is thus brought about and conditions for development and prospective sales are bettered.

**III.** Sanitation is promoted. The movable house promotes health conditions in that: (1) Surroundings may be changed to prevent infection by disease such as hog cholera, contagious white scours, infectious sore mouth, and others. (2) Rotation of hog pastures and lots is easily and cheaply brought about, thus avoiding parasitic infestation, either internal by worms (round, thornheaded, tape, long, pin, and others) or external by lice and mange. (3) A proportionately greater amount of light may enter if the roof is fitted with lights as in the combination house shown in figures 8 and 9. (4) A more thorough airing and lighting is possible in that roof windows, gable doors and windows, and the general door may all contribute. These openings have an area which is proportionately greater in relation to the house capacity than those in the community house. (5) Floors are likely to be more dry and sanitary because the manure, both solid and liquid, is usually deposited in the lot or on the fields. Feeding and watering are usually done outside, this also tending to keep the swine healthier because of the drier, cleaner, and more sanitary floor and bedding. Of course, in periods of extremely cold weather it is sometimes necessary to close the doors, thus preventing free exit of the hogs. It is also true that sometimes in very cold weather hogs will not leave the house and under these conditions the sanitary advantages just mentioned are not obtained. (6) Dust is not so likely to be a menace where dirt floors are depended upon; merely moving the house solves this difficulty. (7) Quarantine of animals may be effectively enforced. The small movable house is a convenient and effectual detention hospital.

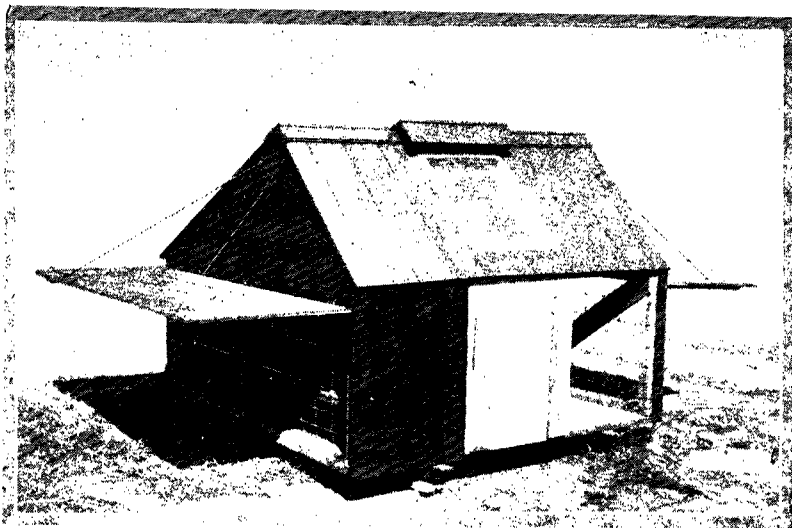

FIG. 8.—Combination individual house. Doors open for shade. Note the wire and fender.

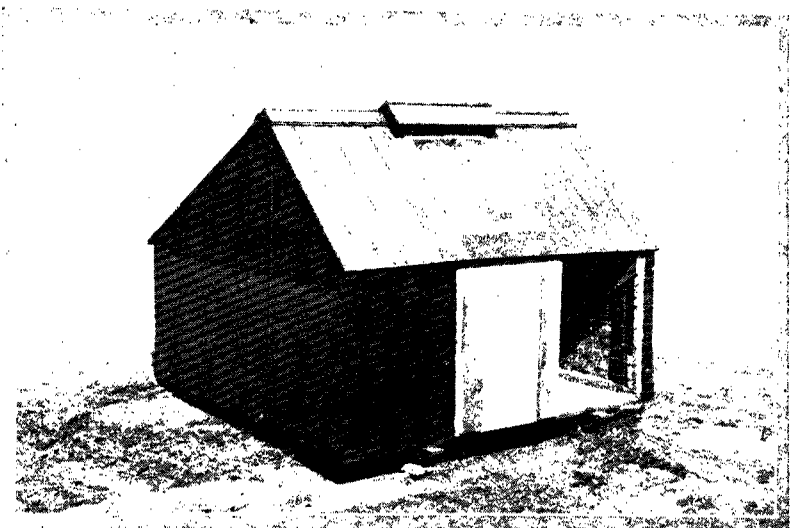

FIG. 9.—Combination individual house with doors closed. This makes a very comfortable winter house.



IV. Construction is simplified. Some features which contribute to economical and easy construction are: (1) Permanent foundations are dispensed with. (2) The building can be constructed under cover during slack times. (3) The location need not be determined definitely because of the movable feature. (4) Prospective planning as to methods and details of construction is reduced to a minimum. The small, individual house may be quickly built by anyone having a working knowledge of carpentry. (5) Pig-saving fenders are not necessary on the sides of the "A"-shaped type because of slanting roof.

V. They are more practical and economical for beginners and owners of small herds. The individual house requires only a small investment to start with. The owner is thus enabled to gradually add to his housing facilities as his herd increases.

VI. They are well adapted to the rented farm. Being a movable, economical unit, the man who rents can better afford this type than the larger one, should the landlord not care to furnish hog houses. The light construction makes the individual house easy to transport from place to place.

VII. Artificial heat in a few pens is easily supplied. In ordinary weather the animals furnish sufficient warmth. However, when extreme cold prevails provision for heating is in order. The common barn lantern usually provides sufficient warmth, but sometimes a small kerosene heating stove may be advantageously pressed into service.

VIII. Fire risk is lessened. Isolation of the small houses insures but slight risk from fire. Furthermore, the danger to other buildings is minimized.

#### COMBINED USE OF COMMUNITY AND INDIVIDUAL HOUSES

The combination of the centralized stationary house and the individual movable house furnishes a most complete system. One house is hardly sufficient no matter how large; it lacks adaptability necessary to meet all of the demands and needs of the swine herd. To have the sows farrow in the centralized house and then transfer them with their litters to an individual house in from two to five weeks, depending upon the weather and other local factors, is a commendable, sane and practical method of procedure. This system is followed widely in the Middle West and with success. The general appearance of the farmstead is improved by a well-chosen combination of both types.

DETAILS OF THE INDIVIDUAL HOUSE  
 KANSAS "A"-SHAPE HOG HOUSE

The Kansas "A"-shape hog house has all desirable features of a movable hog house; these are cheapness, durability, ventilation, and pig fenders or guard rails. It is not quite as large as the common "A"-shape house, but has plenty of room for one sow and her litter.

Bill of Material for the Kansas "A"-Shape House Shown in Figure 7

- 2 pieces No. 1 fir, 4" x 4" x 8'-skids.
- 4 pieces No. 1 yellow pine, 2" x 12" x 14'—floor.
- 6 pieces No. 1 yellow pine, 2" x 4" x 16'—framing.
- 17 pieces No. 2 shiplap, 1" x 10" x 14'-roof and ends.
- 2 pieces trim. 1" x 4" x 12'-door, cleats, and ridgeboard.
- 4 pounds wire nails, 16d.
- 5 pounds wire nails, 8d.
- 3 pairs T-hinges, 4"—for doors.
- 4 screws, 2" (No. 10) for buttons.
- 1 hook—to hold door open.
- ½ gallon barn paint—color to suit.

Cutting Schedule for Framing of Kansas "A"-Shape Individual House

- Cut four 2" x 12" x 14' planks into 7-foot lengths for floor boards. Place skids 3' 8" apart and nail floor boards to them with 16d nails.
- Cut two 2" x 4" sills the length of house measured crosswise of floor boards. Nail sills to floor, 7' outside-to-outside measure.
- Cut one ridge member same length as sills.
- Cut two roof girts equal to length of sills less thickness of two rafters.
- Cut four rafters, 6'-9" long over all, with bottom and top cuts to fit sill and ridge.
- Cut posts, fenders, and filler blocks from remaining 2" x 4" material.
- Select best shiplap for roof and cut 7' long. Use remainder for ends of building.

Note.—Plan No. 72-624 gives complete details for building. See "List of Available Plans" in appendix of this bulletin.

COMBINATION SUMMER AND WINTER HOUSE

The combination house shown in figures 8, 9, and 10 combines both a comfortable farrowing house for early spring and a house providing shade for the hot summer days. The latter feature is particularly desirable when a litter is turned out on pasture where there is no natural shade. The woven-wire fencing keeps the hogs from using any but the main-entrance door in entering or leaving the building. It also makes possible the use of pig fenders and also serves to keep the hogs from crowding the side doors out when closed.

**Bill of Material for Combination House Shown in Figures 8, 9, and 10**

- 2 pieces No. 1 fir, 4" x 4" x 8'—skids.
- 4 pieces No. 1 yellow pine, 2" x 12" x 14'—floor.
- 2 pieces No. 1 yellow pine, 2" x 4" x 16'—framing.
- 8 pieces No. 1 yellow pine, 2" x 4" x 14'—framing.
- 2 pieces No. 1 fencing, 1" x 6" x 16'—cleats and braces.
- 7 pieces No. 2 shiplap, 1" x 10" x 16'—siding.
- 11 pieces No. 2 shiplap, 1" x 10" x 14'—roof and ends.
- 18 feet hog wire, 26".
- 4 pairs T-hinges, 6".
- 4 door hooks, 6"—for doors.
- 5 pounds wire nails, 16d.
- 6 pounds wire nails, 8d.
- 24 feet round iron, 1/4"—hooks and staples.
- 1 roof window, 22" x 28".
- 1 gallon barn paint—color to suit.

**Cutting Schedule for Framing of Combination House**

Cut four 2" x 12" x 14' planks into 7-foot lengths for floor boards. Place skids 3-8" apart and nail floor boards to them with 16d nails.

Cut one 2" x 4" x 16' for sills. Cut sills inside of corner posts and notch for door cleats.

Cut one 2" x 4" x 16' for side plates. Make length equal to length of sill, plus thickness of two posts.

Cut two 2" x 4" x 14' into 7-foot lengths for front and back plates, ridge, and roof support.

Cut one 2" x 4" x 14' for three back posts and one side post.

Cut one 2" x 4" x 14' for three front posts and one side post.

Cut one 2" x 4" x 14' for two back rafters, 5'-10" long.

Cut one 2" x 4" x 14' for four front rafters, 3'-2" long.

Cut two 2" x 4" x 14' for fenders, filler blocks, etc.

Note.—Plan No. 72-632 gives complete details for building. See "List of Available Plans" in appendix of this bulletin.

**DETAILS OF THE COMMUNITY HOUSE**

The construction of any building will vary somewhat with the ideals of the individual, but in order that it may be of the greatest service and efficiency the following points should be given careful consideration.

**Floor and Foundation.**—A centralized hog house should be relatively permanent. The first requirement of any permanent structure is a good foundation. A frame hog house is not a heavy building, but it should have a foundation wall at least six inches thick and extending below the frost line, which will be from 18 to 30 inches deep for most parts of Kansas. The wall should have a footing of from 8 to 12 inches, depending upon the firmness of the

soil. It should also extend above the ground 8 to 12 inches in order to protect the sills from soil moisture and thus prevent decay.

A warm, comfortable floor for farrowing pens is made by laying a No. 2 grade of 5" x 8" x 12" building tile on a sand or gravel base and covering them with 1 1/2 inches of concrete. (Figs. 3 and 4.) This construction provides air space in the floor which serves as insulation against cold and dampness from the ground. A similar effect can be obtained by using 4 to 8 inches of crushed rock for a

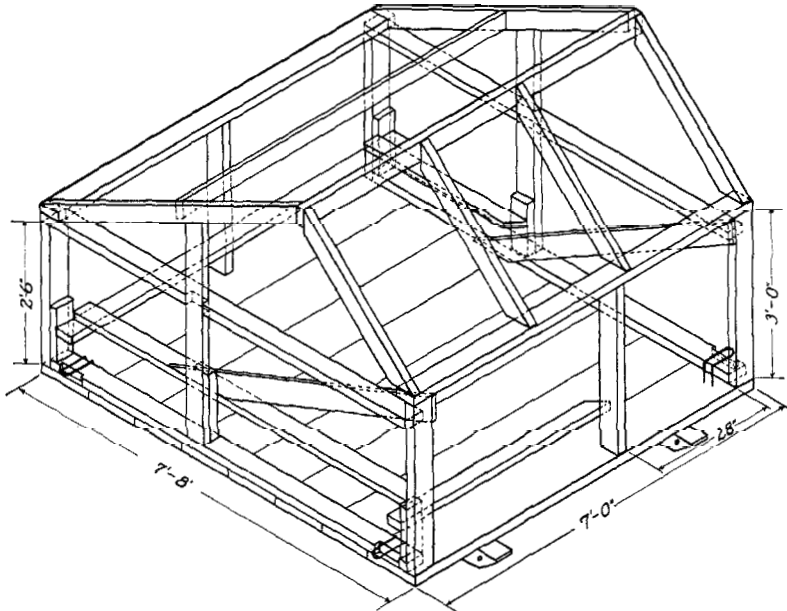

Fig. 10.—Framing for combination house shown in figures 8 and 9.

base and placing the floor over this. The alley floor may be of solid concrete, 3 or 4 inches thick. Floors should slope about 1/4 inch per foot, toward drains or gutters provided to carry away the water. Hog-house floors should never be finished with a steel trowel, as this makes too slippery a surface when wet, but rather a wood float or a float covered with burlap or carpet should be used.

**Doors.**—Doors should have low sills and good approaches to eliminate the danger of injury and nervousness among the animals. Outside pen doors (Fig. 11) should be 30 inches wide and 36 inches high.

**Windows.**— Ample sunlight must be provided and steel-frame, water-tight, wired-glass roof windows that are on the market offer a convenient method of getting sunlight where most desirable. These may be secured to fit on top of sheathing boards and between rafters without additional framing. There should be one square foot of glass area for each 12 to 15 square feet of floor space and so placed as to throw the sun pattern on the floor during the farrowing period. For correct window location see “Sunshine Table for Kansas,” page 42.

**Pens.**— The size of farrowing pens will vary slightly under different conditions, but in no case should they be less than 6 by 8 feet.

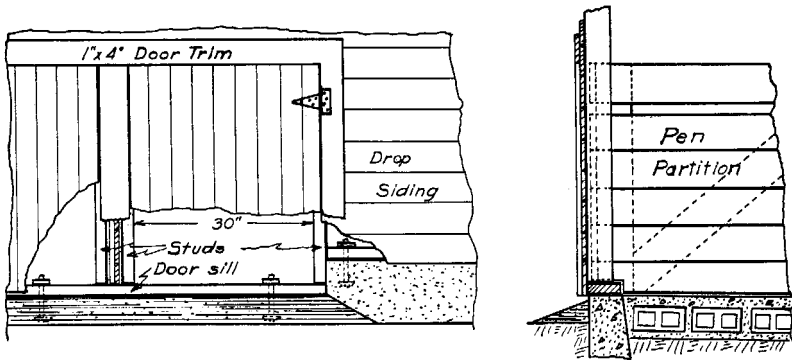

Fig. 11.—Detail of outside pen doors for community house. (The wood sill in the door may be omitted if stud sockets are used.)

**Pen Gates and Partitions.**— Pen gates and partitions are preferably made removable (figs. 12 and 13), so that all or any number of pens may be thrown into one large pen or feeding floor for growing pigs or stock hogs in times other than the farrowing seasons. Removable partitions require some place to store them when not in use. This is found by placing them along the wall, since usually it will not be necessary to have all the pen doors open, or they may be nested in one end of the building.

**Fenders.**— All farrowing pens must be provided with pig fenders or guard rails which consist of 2 by 4 planks supported by iron brackets all around the pen about 8 inches from the floor and extending 8 inches from the walls and partitions. (Fig. 14.) Satisfactory steel gates, partitions, and fenders may be purchased already manufactured, but these are higher in first cost than those of wood construction.

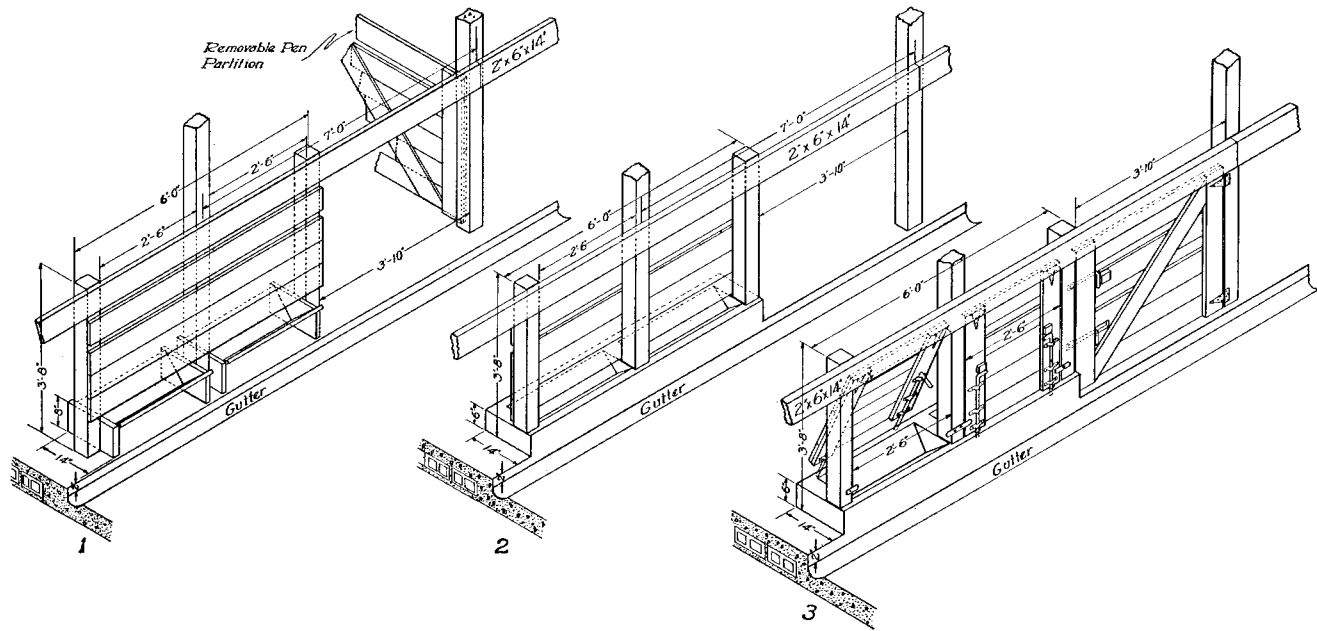

FIG. 12.—Three arrangements of pen fronts and troughs. (1) Removable wood trough in solid panel. (2) Concrete trough and solid front panel. (3) Concrete trough with hinged panels.

**Troughs.** — Individual troughs for farrowing pens may be of concrete, wood, or steel. The concrete troughs are cast at the time the floor is placed and are fixed, while the other two types may be either fixed or movable. Much of the steel pen equipment has troughs hung in the gates and which are removable with the gates. Figure

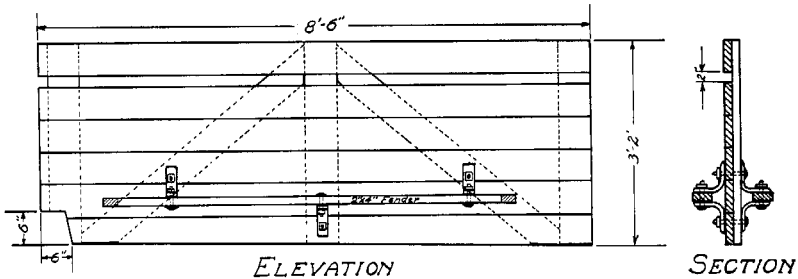

FIG. 13.—Removable pen partition with fenders attached.

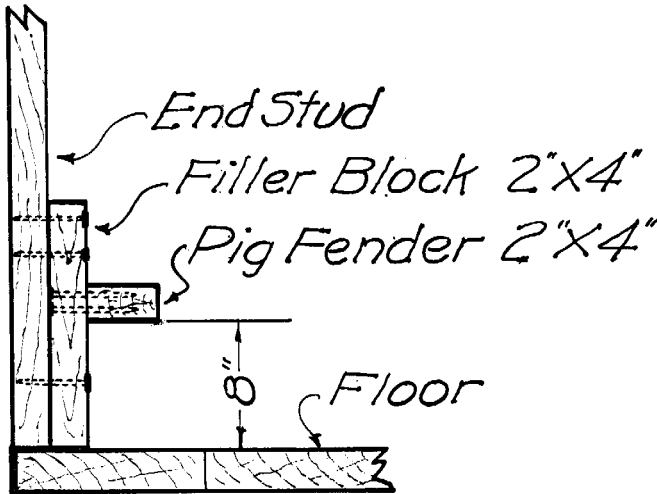

FIG. 14.—Fender detail for Kansas "A"-shape hog house. (Fig. 7.)

12 shows a removable wood trough in wood pen front and two types of wood pen front with concrete troughs.

**EQUIPMENT FOR FEEDING**

**Self-feeders.** — Self-feeders as a means of feeding fattening pigs have come into very common use because they save time, labor, and feed. They are designed to keep a supply of grain or other concentrated feed constantly before the pigs, and at the same time to

prevent the pigs wasting feed. The feeder must be designed also to protect the contents against waste due to wind or rain. A feeder should be constructed with two or more compartments so more than one feed can be made available.

Many self-feeders are a failure because they either clog and fail to furnish the animal enough feed, or else they run too freely and

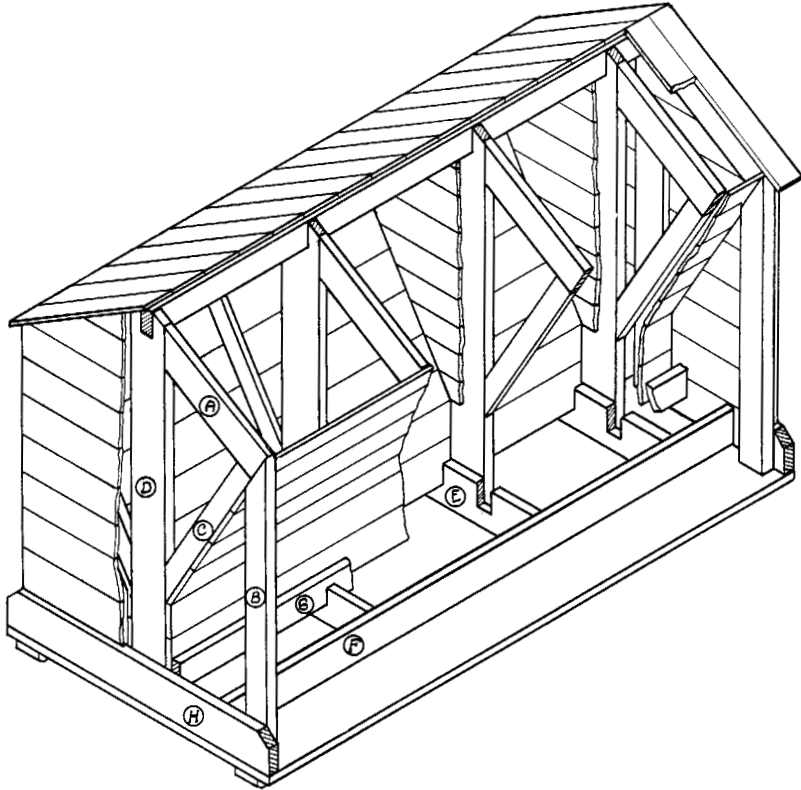

FIG. 15.—Oblique view of Kansas feeder. A feeder that has proved most satisfactory among users.

waste feed, The feeder shown in figures 15 and 16 is so constructed that the waste of feed is reduced to a minimum and yet there is plenty of feed available at all times provided a supply is kept in the feeder. Most feeders, if they clog, do so where the two slopes of the hopper bottom meet, and this point is often near the opening. One of the principal features of the Kansas feeder is the straight vertical drop of the feed through the 6-inch throat of the feeder. This



places the clogging area a considerable distance above the feed opening and away from the animals' moist breath, and thus eliminates much of the danger of clogging. Also, the feed opening is near the floor of the feeder, and feed, in order to waste, must fill to the top of the 6-inch rail, which is not likely to occur.

*Note—Roofing placed under hinges covers Ridge joint of Beards.*

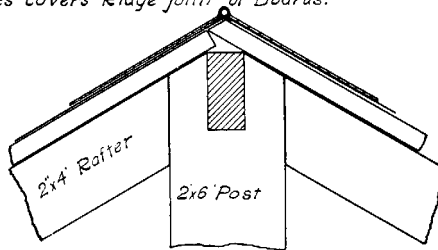

FIG. 16.—Roof detail of Kansas feeder.

**Bill of Material for Feeder Shown in Figure 15**

- 3 pieces No. 1 dimension, 2" x 6" x 8'.
- 2 pieces No. 1 dimension, 2" x 6" x 10'.
- 1 piece No. 1 dimension, 2" x 6" x 12'.
- 7 pieces No. 1 dimension, 2" x 4" x 8'.
- 5 pieces No. 1 dimension, 2" x 4" x 10'.
- 250 board feet, dressed and matched, 1" x 6" x 16'.
- 3 pounds wire nails, 16d.
- 2 pounds wire nails, 8d.
- 2 pairs strap hinges, 8".
- ½ square prepared roofing.
- 1 gallon paint.

**Cutting Schedule for Framing of Kansas Feeder Shown in Figure 15**

- Cut three 2" x 6" x 8' for feed rails (F) and end rails (H).
- Cut two 2" x 6" x 10' for center post (D), four pieces, 5' long.
- Cut one 2" x 6" x 12' for center post, one piece (D) 5' long and three pieces (E) 2'-2½' long.
- Use for skids, two 2" x 4" x 8'.
- Use for upper feed rail (G), two 2" x 4" x 8'.
- Use for ridge, one 2" x 4" x 8'.
- Cut two 2" x 4" x 8' for corner post (B), four pieces, 4' long.
- Cut five 2" x 4" x 10' for hopper posts (C), ten pieces 2'-10" long and for rafters (A) ten pieces 22" long.

**Note.**—Plan No. 77-622 gives additional details of cutting.

The feeder shown in figure 17 is a larger size and is designed to hold a load of shelled corn and several bags of tankage or other prepared feeds. The filling door rests against the wagon when open for filling and catches grain that would otherwise fall to the ground.

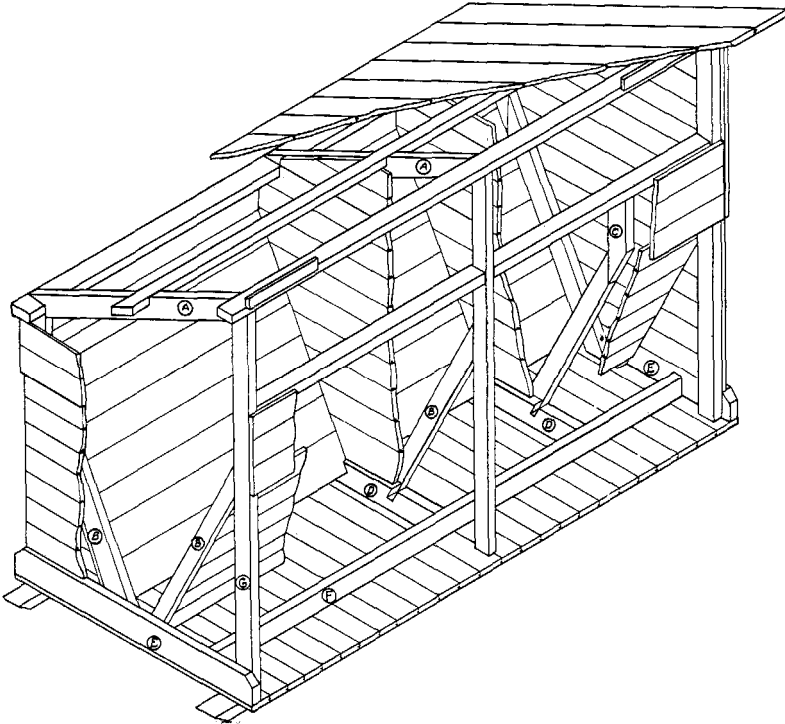

FIG. 17.—Large type feeder. This feeder is designed to hold a larger supply of feed than the one shown in figure 15.

**Bill of Material for Feeder Shown in Figure 17**

- 8 pieces No. 1 dimension, 2" x 4" x 12'.
- 3 pieces No. 1 dimension, 2" x 4" x 14'.
- 1 piece No. 1 dimension, 2" x 6" x 10'.
- 68 pieces dressed and matched, 1" x 6" x 10'.
- 12 pieces dressed and matched, 1" x 6" x 14'.
- 12 pounds wire nails, 8d.
- 3 pounds wire nails, 16d.
- 2 pairs T-hinges, 6".
- 1 gallon paint.

**Cutting Schedule for Framing of Large Self-Feeder Shown in Figure 17**

Use two 2" x 4" x 10' for feed rails (F).

Use two 2" x 4" x 12' for skids.

Use three 2" x 4" x 12' for plates and roof support.

Cut three 2" x 4" x 12' for front posts (G), three pieces 7' long, and for rafters (A) three pieces 4'-9½" long.

Cut one 2" x 4" x 12' for hopper posts (B), two pieces 4'-5" long, and for short posts (C) two pieces 21" long.

Cut one 2" x 4" x 12' for two door sills, and for partition rail (D) two pieces 3' long.

Cut three 2" x 4" x 14' each as follows: Hopper post (B), two pieces 4'-5" long; back hopper post, one piece 4'-10" long.

Cut one 2" x 6" x 10' for end rails (E), two pieces 5' long.

**Note.**—Plan No. 77-626 gives details of framing.

**Feeding Racks.**—Any of the legume hays—alfalfa, clover, sweet clover, cowpea or soybean—when of fine quality, offer one of the most valuable means of supplementing corn or other home-grown grains, supplying three very important elements in the sow's ration; that is, bulk, protein, and lime or mineral matter. The legumes are also laxative in their effects.

A rack provides the most practical and economical method of feeding legume hays to swine. The rack should have a tight bottom to catch the leaves and fine particles that break off when feeding or handling. The trough can be used for feeding grain or other protein supplements. The rack should be of sufficient size so as not to require filling daily. If of large size and kept out of doors it may be well to provide a cover to protect the hay from rain. The guards should have a steep slope to prevent the hay from clogging. A good type of rack is shown in figure 18.

**Bill of Material for Rack Shown in Figure 18**

- 1 piece No. 1 fir, 4" x 4" x 14'—skids.
- 5 pieces No. 1 yellow pine, 2" x 4" x 12'—posts and framing.
- 2 pieces No. 1 shiplap, 1" x 10" x 14'—floor.
- 1 piece No. 1 yellow pine, 1" x 13" x 12'—floor strips.
- 6 pieces No. 1 yellow pine, 1" x 3" x 10'—feeder slats.
- 4 pieces No. 2 yellow pine, 1" x 8" x 12'—hopper sides.
- 4 pieces No. 2 yellow pine, 1" x 8" x 14'—ends.
- 1 piece No. 2 yellow pine, 1" x 8" x 12'—ends.
- 2 pounds wire nails, 6d.
- 2 pounds wire nails, 8d.
- 1 pound spikes, 16d.

**Note.**—Plan No. 77-624 gives details for building.

**Feeding Floors.**— Feeding floors are almost essential to profitable pork production, especially in wet weather. They save feed from getting trampled into the mud (fig. 19), keep the feed clean, save time and labor in feeding, add to the attractiveness of the swine-production plant, and make pigs more thrifty and contented.

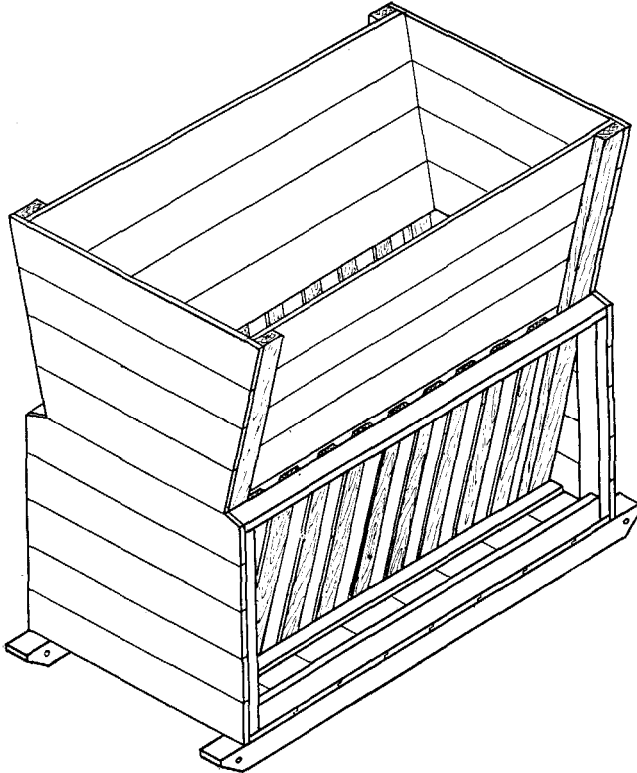

FIG. 18.—Alfalfa rack. This is a suitable rack for feeding alfalfa or other legume hays to swine or sheep. Plan No. 77-624.

Some of the factors that should be given consideration in locating and building a feeding floor are: Drainage, sanitation, durability, nearness to corncrib, location as to pasture and winter quarters, ease of cleaning, and cost. In a feed lot that seldom gets muddy, it is doubtful if the saving in feed due to the floor would pay for the cost of construction except over a very long period of use. This should be considered along with the cost.

Concrete probably makes the most desirable feeding floor. If such a concrete floor is located on firm, well-drained soil, there is no need of a foundation other than the soil after it has been cleared of grass and other perishable matter and brought to the proper grade. The floor should have a slope of from one-eighth to one-quarter of an inch per foot and be provided with a curb about 4 inches high to prevent feed from being pushed off. Also, a curb or apron should extend 12 inches below grade to prevent hogs from rooting under the floor and allowing it to break down. A gutter should be provided just inside the curb along the lower side.

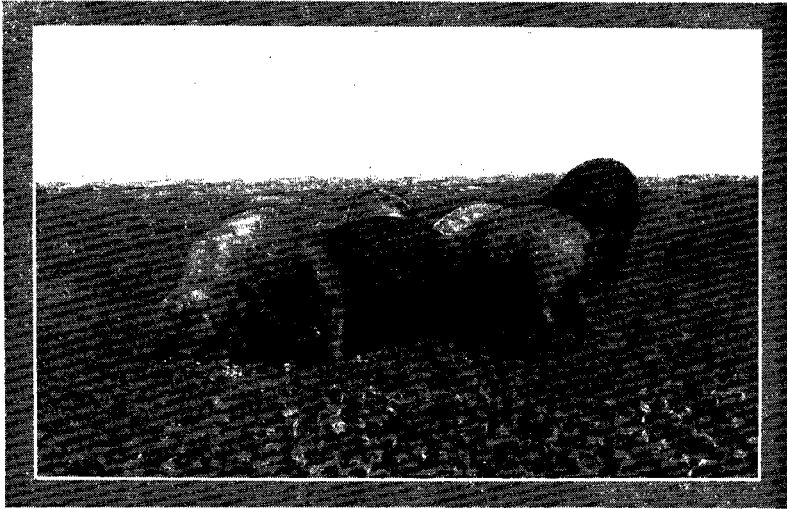
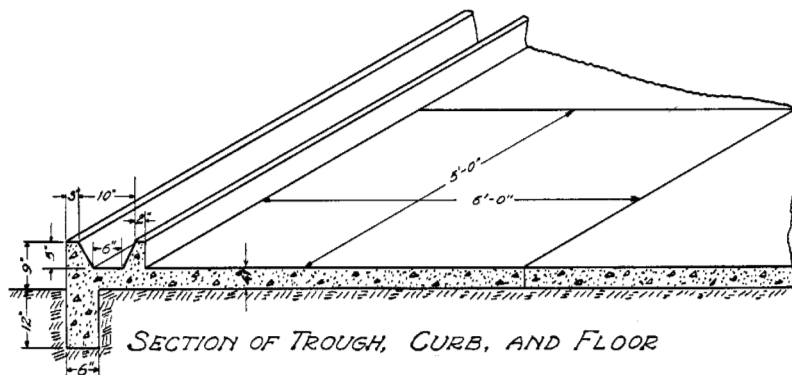

FIG. 19.—Pigs fed in the mud are not the best money makers.

The floor should be not less than 4 inches thick and of one-course construction, of 1-2  $\frac{1}{2}$ -5 concrete. If the best grades of sand and gravel are not available, a richer mixture should be used: 1-2-4 or 1-2-3. A concrete trough can well be put along one or more sides of the floor, or if preferable, through the center, so that hogs may more easily get on both sides of it.

The concrete should be laid in sections about 5 or 6 feet square. A two-bag batch of 1-2  $\frac{1}{2}$ -5 concrete will lay one 5' x 6' section of 4-inch floor. Each 15 square feet of 4-inch floor will require 1 bag of cement,  $2\frac{1}{4}$  cu. ft. of sand, and  $4\frac{1}{2}$  cu. ft. of gravel. Each 7 lineal feet of curb and apron will require 1 bag of cement,  $2\frac{1}{4}$

cu. ft. of sand, and  $4\frac{1}{2}$  cu. ft. of gravel. These figures are based on 1-2½-5 mixture, one-course 4-inch floor, 6-inch apron 12 inches below grade, and a 6-inch curb 9 inches above grade. (Fig. 20.) The surface should be finished with a wood float rather than a steel trowel, since the latter produces a surface that is too slippery when wet. Not less than 15 square feet of floor should be provided for each hog it is expected to accommodate.



*SIZE OF FLOOR :-15 sq ft of floor per hog.*

*MATERIAL :-1 2½:5 concrete, made from good cement and clean sand and gravel*

*MATERIAL REQUIRED :- 1 bag cement, ½ yd sand, and ½ yd gravel per 15 sq ft of 4" floor or per 7 linear feet of curb and apron.*

FIG. 20.—A concrete feeding floor soon pays for itself in a muddy lot.

**Feeding Troughs.**— Many types of hog troughs are used by swine producers. All troughs, regardless of type, should be constructed with these ideas in mind: (1) Ease of cleaning and (2) suitability for the class of hogs to be fed. A large percent of pig losses is due to scours. Scours are caused by using dirty feed troughs or improper feeding.

Four types of troughs are shown in figures 21 to 24. Figure 21 shows a flat-bottom trough for feeding small pigs. This is a shallow trough, but one very easily constructed and satisfactory. Figure 22 shows partitioned trough designed to keep pigs out of the trough, and the larger pigs from pushing the smaller ones away. The common "V"-shaped trough is shown in figure 23 and the double "V"-shaped trough in figure 24.

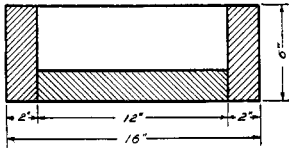

FIG. 21.— Small rectangular trough for feeding small pigs.

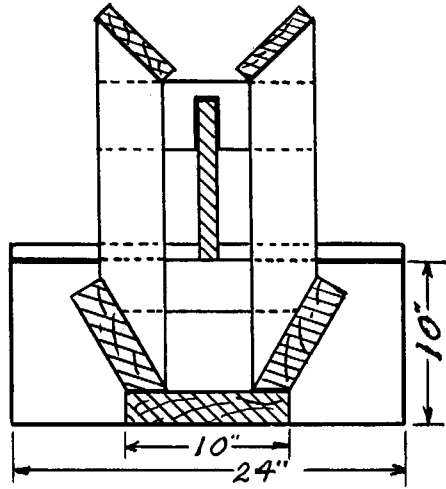

FIG. 22.— Partitioned trough where every pig gets its share.

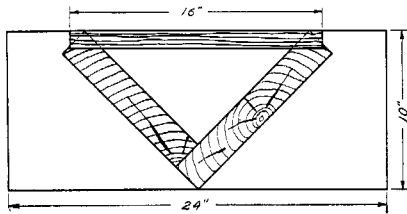

FIG. 23.— The common "V"-shaped trough for large hogs.

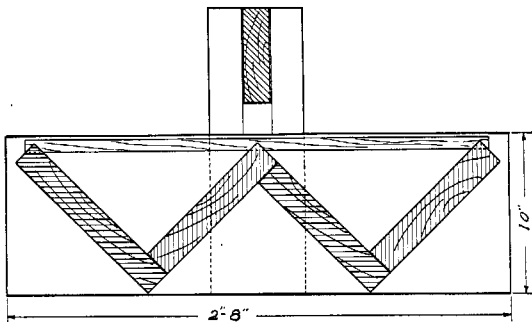

FIG. 24.— The double "V" trough.

Small pigs while still suckling should also be trough fed so as to be accustomed to this method of feeding at weaning time. They require a shallower trough, however, than the large, deep trough used for old hogs.

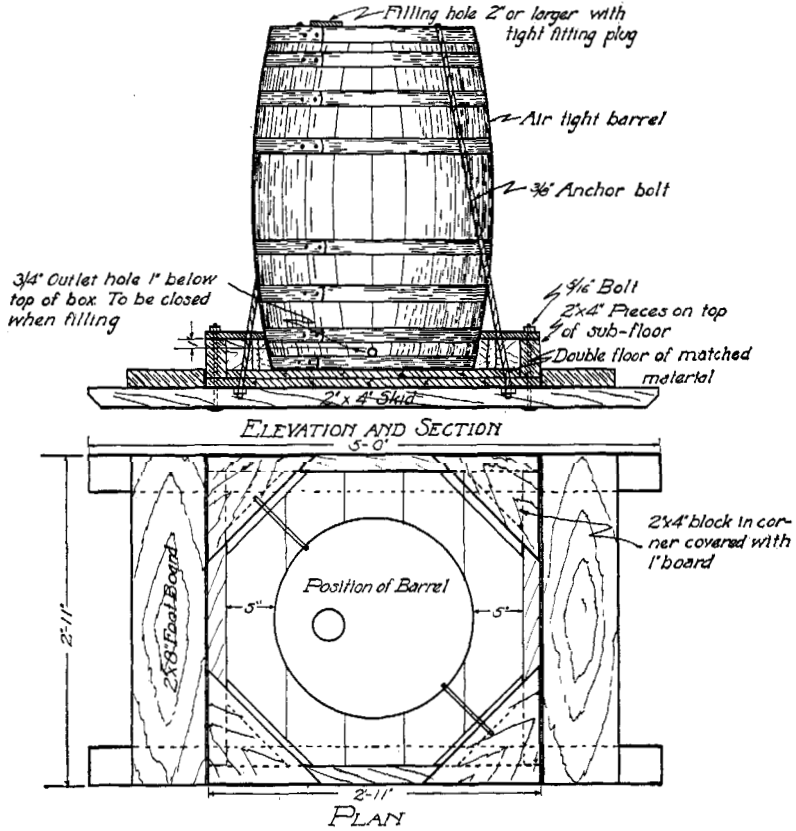

FIG. 25.—A portable barrel waterer that is automatic. The wood-stave barrel shown is suitable if it does not dry out and leak air. The action of this waterer depends upon its being air tight above the water line in the drinking trough. A steel barrel will be more dependable.

**Waterers.**—Hogs require water, not in as large quantities as some other stock, but what they need they should have regularly if they are going to thrive best, "All they will drink" once or twice a day is not sufficient, especially in warm weather, but rather, they should have all they will drink all the time.

Most, if not all, feeds contain some water. Some contain a very



large percent of water. The animal, of course, uses that water in its system, otherwise it would drink much more than it does. Even on succulent pasture it is necessary to furnish each hog from 1 to 1<sup>1</sup>/<sub>2</sub> gallons of water daily in the warm summer days. Of course, less water is required in cold weather, but in cold weather drier feeds are used, so the amount is not much reduced.

Any excess of water taken into the system will usually prove an advantage rather than a detriment, since all the excess will be thrown off anyway in the body wastes and in that way flush the entire system. About the only time an excess of water will prove dangerous is when the animal has been deprived for a time of what it wanted to drink, and then suddenly allowed to have all it desires. If some means is provided for a continuous supply this condition will not exist.

The barrel waterer shown in figure 25 is a convenient, portable water fountain that can be made at a slight cost, requiring only an airtight wood or steel barrel and the box mounted on skids. If the barrel is airtight this waterer is automatic as long as there is any water in the barrel, and if properly made, it will not overflow. The only precautions necessary are that the barrel be *airtight* and fitted with an *airtight* plug or cap at the top, and that the outlet hole be an inch below the top edge of the box so that the water will cover it and keep air out until the water level in the box has been lowered.

To fill the barrel, plug the outlet hole and remove filler plug. Keep the outlet hole plugged until the barrel is completely filled and the filler plug or cap is tightly replaced. The plug may now be removed from the outlet opening and water will flow out until the outlet is covered. This will stop air from entering the barrel and no more water will flow out until the level in the trough has been lowered. If the water does overflow the trough it indicates that either the outlet hole is not low enough or the barrel is not airtight.

A cheap automatic waterer may be made from a half barrel set in the ground and connected to a pipe line by means of a float valve. The front half of the barrel is cut away 3 inches below the center, the back half 3 inches above the center, which make a 6-inch offset. (Fig. 26.) The back or higher part covers the float and gives room for it to rise above the water level. The front part is boarded over and has two drinking holes cut in the cover. If the barrel has solid heads in both ends, two waterers may be made from one barrel. The pipe connection and valve must necessarily be placed in the front part of the barrel so the float lever can extend back into the float chamber. A board should be fitted into the front part of the barrel

about 3 inches below the drinking holes. This serves two important purposes. It is a means of preventing chickens and small pigs from entering or being pushed into the water through the drinking holes. Also, it protects the valve from damage due to animals or foreign material being pushed into it. This is important since if the valve or float lever is out of adjustment the waterer will overflow.

A "cut-off" or "stop-and-waste" valve should be installed in the line near the water so that it may be shut off in case of trouble with

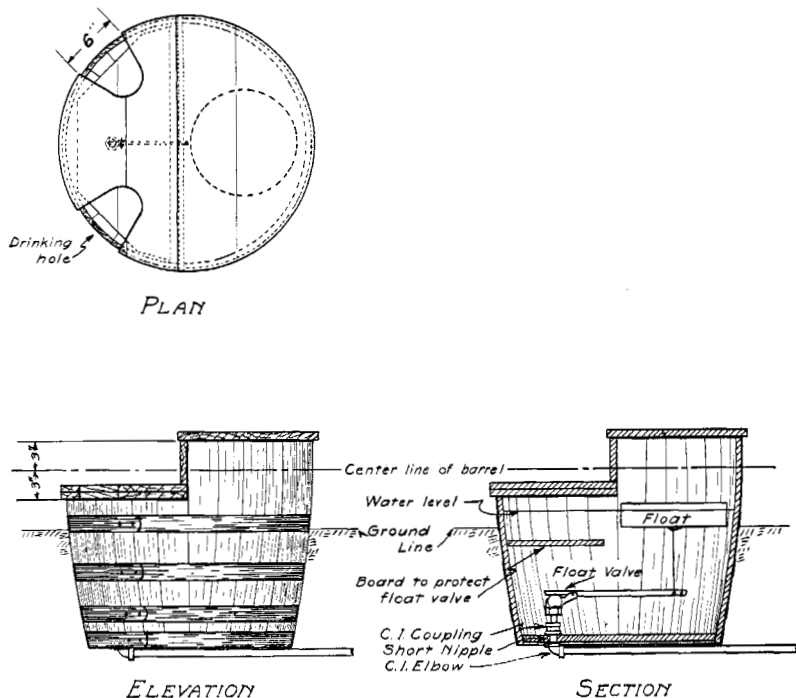

FIG. 26.—Half-barrel waterer. This is a float-controlled waterer that can be used out of doors the year round.

the float. Also on lines where the pressure is high, this cut-off valve may be kept partly closed, which will reduce the rate of flow and allow the float valve to seat more easily.

The waterer should be so set in the ground that about 3 inches of the front or drinking part is out of the ground. In winter the whole waterer except the drinking holes should be covered with manure to prevent freezing. If it is installed in a protected place and treated this way, it will seldom if ever freeze more than a thin film of ice in the most severe Kansas winter weather.

EQUIPMENT FOR CARE AND MANAGEMENT

**Pig Creeps.**-Weaning time is an important period for the growing pig and unless some attention has been given to the cultivation of his appetite for those feeds upon which he will have to live when deprived of his mother's milk, it will be difficult to get him by this period in good condition; but if taught to eat, weaning will be fairly easy. Creeps by means of which the young nursing pigs can find room away from their mothers and satisfy their increasing appetites on some choice feeds especially proportioned to their needs are one of the big helps in getting young porkers safely past this weaning period. A shallow trough similar to the one shown in figure 21, enclosed by a creep which will keep out the older hogs, will give the small pigs an opportunity to try these feeds unmolested by the larger animals.

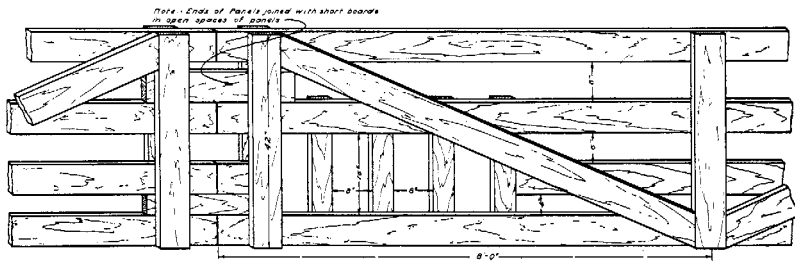

FIG. 27.—Movable fence with pig creep. Portable fence panels are convenient for constructing temporary fence. A pig creep should be the right width to allow pigs to pass and to keep back older hogs, rather than to make the pigs squeeze under or over a narrow board.

The following points should be kept in mind in making creeps: Pigs will crowd in spite of all one can do, but if the openings are made the proper size, at least 8 inches wide, and the slats run up and down, there will be little danger of injury. The openings should be made so the pigs will not be required to squeeze under or over a board and thus be subjected to either back injury or rupture. The best openings are high, but narrow enough to keep back the larger hogs. Pigs can be seriously injured in jamming and crowding over and under fence boards.

A temporary fence is oftentimes useful in enclosing pens, lots, or small portions of pastures which are to be used by small pigs, also in the construction of creeps for small pigs or in the making of sale rings and runways, or in loading or crating stock. The fence should be constructed in such a manner that it will be light and serviceable,

and easily stored in a small space when not in use. It is best to make this temporary fence in panels similar to a gate, and support these panels on standards. Figure 27 shows a fence panel of this type.

**Breeding and Holding Crate.**—It is often desirable to mate a small sow with a large, heavy boar, and there is danger of injury to the sow unless some mechanical device is used to help bear the

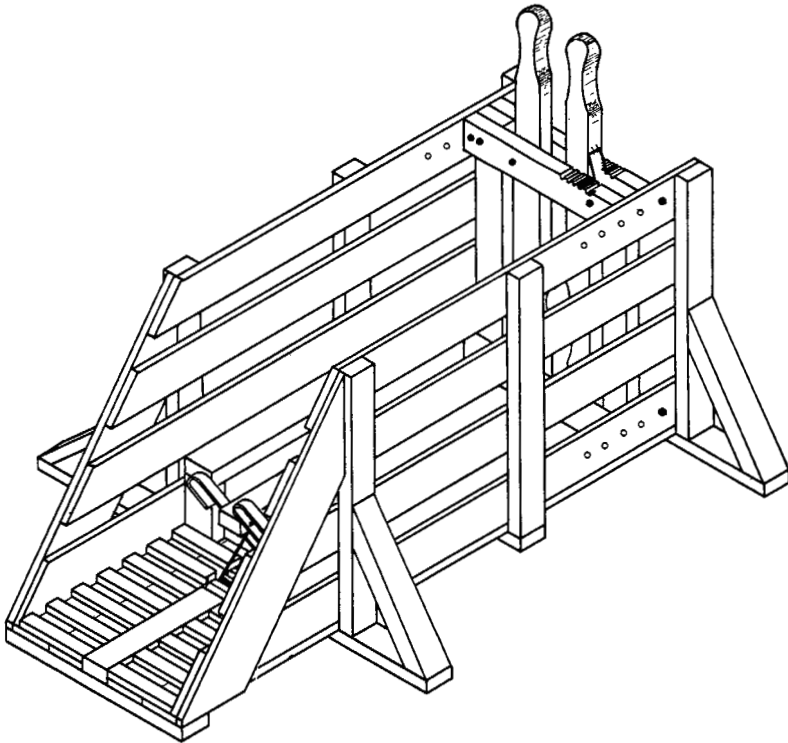

FIG. 28.—Breeding and holding crate.

weight of the boar. A breeding crate has these advantages: It allows the breeder to use a mature boar on immature gilt or vice versa without danger of injury, and it conserves the vigor of the boar. It might be said to have these disadvantages: It requires more time and patience; boars have to be taught to use it; and some breeders believe that a sow is more likely to miss conception if a crate is used.

The crate shown in figure 28 is constructed in such a way that it will serve a twofold purpose. Many times in ringing, ear tagging,

or vaccinating it is necessary to put the hog into a crate in order to hold him until the work can be accomplished. The crate shown is designed with this purpose in mind.

**Bill of Material for Breeding and Holding Crate Shown in Figure 28**

- 5 pieces No. 1 yellow pine, 2" x 4" x 12'.
- 2 pieces No. 1 yellow pine, 2" x 4" x 14'.
- 1 piece No. 1 board, 1" x 2" x 18'.
- 2 pieces No. 1 boards, 1" x 6" x 14'.
- 5 pieces No. 1 boards, 1" x 6" x 12'.
- 8 carriage bolts,  $\frac{3}{8}$ " x  $7\frac{1}{2}$ ".
- 3 carriage bolts,  $\frac{1}{2}$ " x  $6\frac{1}{2}$ ".
- 1 strap iron,  $\frac{3}{8}$ " x  $1\frac{1}{2}$ " x 7'.
- 1 round iron,  $\frac{1}{2}$ " x 30".
- 2 round irons,  $\frac{1}{2}$ " x 28".
- 2 pounds wire nails, 6d.
- 1 pound wire nails, 10d.
- 1 quart paint.

**Note.**—Further details are given in plan No. 77-662.

**Cutting Schedule for the Breeding and Holding Crate Shown in Figure 28**

Cut one 2" x 4" x 12' into two pieces 4'-6" long for floor sills, and one piece 3' long for a post.

Cut one 2" x 4" x 12' into two pieces 4'-6" long for gate, and one piece 3' long for a post.

Cut one 2" x 4" x 12' into four pieces 3' long for posts and gate upright.

Cut one 2" x 4" x 12' into four pieces 2' long for gate bars, and one piece 3' long for a post.

Cut one 2" x 4" x 12' into one piece 3'-10" for lift, one piece 2'-4" for short floor sill, one piece 2'-6" for short sill, and one piece 3' long for a post.

Cut one 2" x 4" x 14' into four pieces 2'-6" long for foot rests and filler blocks, and four pieces 8" long for foot rests.

Cut one 2" x 4" x 14' into one piece 7' long for lifting device, and four pieces 21" long for side braces.

Cut two 1" x 6" x 14' into four floor boards 7' long.

Cut two 1" x 6" x 12' for top and bottom boards on sides.

Cut two 1" x 6" x 12' for center boards on sides.

Cut one 1" x 6" x 12' for diagonal braces and filler blocks.

**Note.**—Plan No. 77-662 gives details of cutting and building.

**Castrating Trough.**—The trough shown in figure 29 is convenient when castrating or vaccinating pigs weighing up to 75 or 100 pounds.

**Loading Chute.**—As a large proportion of the hogs marketed are hauled to the local market by truck, it is essential to have some convenient method of getting the animals loaded. The portable loading chute shown in figure 30 is a convenient piece of equipment for the hog raiser to have for this purpose.

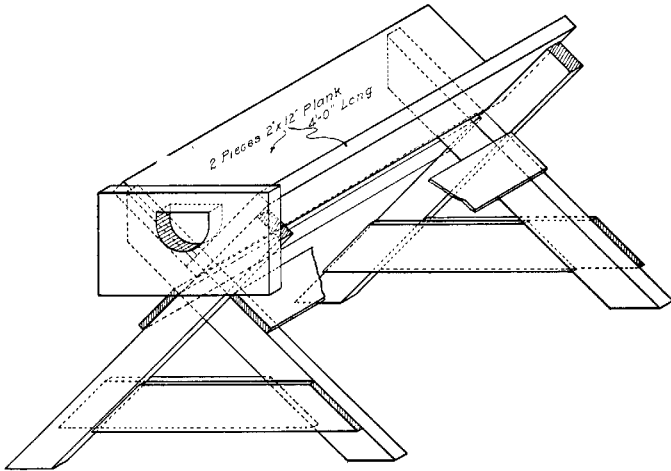

FIG. 29.—A convenient trough for use when castrating or vaccinating pigs.

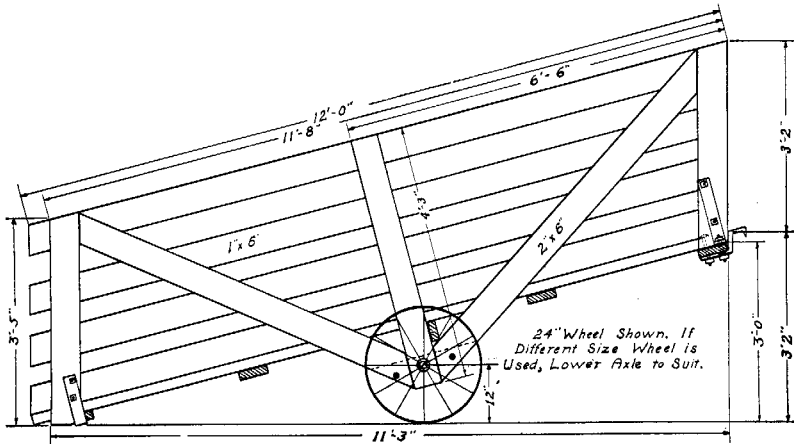

FIG. 30.—A loading chute that is easily moved about.

**Bill of Material for Loading Chute Shown in Figure 30**

- 8 pieces No. 1 rough fencing, 1" x 6" x 12'—sides.
- 3 pieces No. 1 plank, 2" x 12" x 12'—floor.
- 3 pieces No. 1 yellow pine, 2" x 6" x 14'—braces.
- 3 pieces No. 1 yellow pine, 2" x 6" x 10'—braces.
- 2 pounds wire nails, 16d.
- 3 pounds wire nails, 8d.
- 16 carriage bolts, 3/8" x 4".
- 4 carriage bolts, 3/8" x 5".
- 24 pounds iron, 1/2" x 2".
- 4 feet pipe, 1", for axle.
- 4 cotter keys, 1/4" x 2 1/2".
- 4 washers, 1 1/4".

**Cutting Schedule for Loading Chute**

- Cut eight 1" x 6" x 12' for sides.
- Cut three 2" x 12" x 12' for floor.
- Cut two 2" x 6" x 14' for diagonal braces on each side.
- Cut one 2" x 6" x 14' for middle posts and sills.
- Cut two 2" x 6" x 10' for four end posts and two sills.
- Cut one 2" x 6" x 10' for two sills and axle blocks.

**Note.**—Plan No. 77-672 gives details for building.

**Shipping Crate.**—A large number of hogs that are sold, especially breeding stock, have to be shipped by express to their new owners. For this purpose a substantial, roomy crate should be available for each animal. (Fig. 31.) Shipping crates are usually built in about four sizes to accommodate various sizes of animals. The sizes given below are inside dimensions.

Weight of animal.	DIMENSIONS OF CRATE.		
	Width.	Height.	Length.
Up to 100 pounds.....	1'-0"	2'-0"	3'-0"
100 pounds to 225 pounds.....	1'-6"	2'-9"	4'-4"
225 pounds to 500 pounds.....	2'-2"	4'-0"	7'-0"
Over 500 pounds.....	2'-2"	4'-0"	7'-0"

Shipping crates may be constructed so as to be useful for purposes other than shipping. They may be used as temporary fence panels, especially on sale day. Also, if both ends are made removable, they can be set end to end and used as a chute leading into the sale ring.

**Cautions in Building.**—Do not leave cracks over 3/8 inch wide in the floor of the crate. Be sure the sides are tight against the bottom, and have close spacing of slats for at least a foot above the bottom. This prevents injured and perhaps broken legs. Place enough cleats on top to prevent the hog's jumping over the top or even getting his head through the cracks. See that the crate is well nailed throughout.

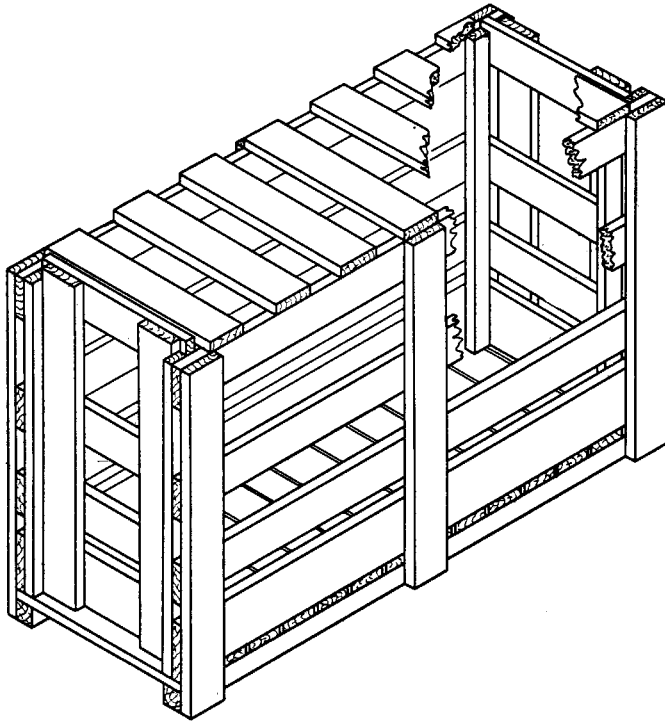

FIG. 31.—Shipping crate.

**Bill of Material for Shipping Crate**

- 1 piece No. 1 yellow pine, 2" x 2" x 10'—skids.
- 2 pieces No. 1 board, 1" x 2" x 12'—gate guides.
- 1 piece No. 1 board, 1" x 6" x 14'—sides and gates.
- 9 pieces No. 1 boards, 1" x 4" x 12'—floor, top, and side framing.
- 2 pounds wire nails, 6d.
- 1 pound wire nails, 8d.

**Note.**—The material listed will make a crate for a hog weighing 225 pounds.

**Illustrations for Building Shipping Crate**

Build the floor first, then each side as a unit and assemble the crate by nailing sides to floor skids and nailing cleats across top. Removable end gates are then built and slipped into place.

**Note.**—Plan No. 77-682 gives more complete details of construction.



**SUNSHINE TABLE FOR KANSAS**

The following tabulation shows correct window location in hog house for different farrowing dates and different lengths of pens:

LATITUDE AND DATE.	Distance from window line to north side of pen (at floor).					
	6 feet.		8 feet.		10 feet.	
	Height of top of window above floor line.					
	Noon.	10 a. m. 2 p. m.	Noon.	10 a. m. 2 p. m.	Noon.	10 a. m. 2 p. m.
<b>37°</b>						
Feb. 1.....	4' 4"	4' 0"	5' 10"	5' 4"	7' 9"	6' 7"
Mar. 1.....	6' 7"	5' 10"	8' 1"	7' 6"	10' 2"	9' 9"
Apr. 1.....	9' 5"	9' 8"	12' 6"	12' 10"	15' 8"	16' 2"
<b>38°</b>						
Feb. 1.....	4' 2"	3' 10"	5' 7"	5' 1"	6' 11"	6' 4"
Mar. 1.....	5' 10"	5' 7"	7' 10"	7' 6"	9' 9"	9' 4"
Apr. 1.....	9' 0"	9' 3"	12' 0"	12' 4"	15' 0"	15' 6"
<b>39°</b>						
Feb. 1.....	4' 0"	3' 8"	5' 5"	4' 11"	6' 8"	6' 1"
Mar. 1.....	5' 8"	5' 5"	7' 7"	7' 3"	9' 7"	9' 1"
Apr. 1.....	8' 9"	8' 11"	11' 7"	11' 11"	14' 6"	14' 11"
<b>40°</b>						
Feb. 1.....	3' 10"	3' 6"	5' 2"	4' 8"	6' 5"	5' 10"
Mar. 1.....	5' 5"	5' 3"	7' 3"	7' 0"	9' 1"	8' 9"
Apr. 1.....	8' 5"	8' 7"	11' 2"	11' 6"	14' 0"	14' 4"

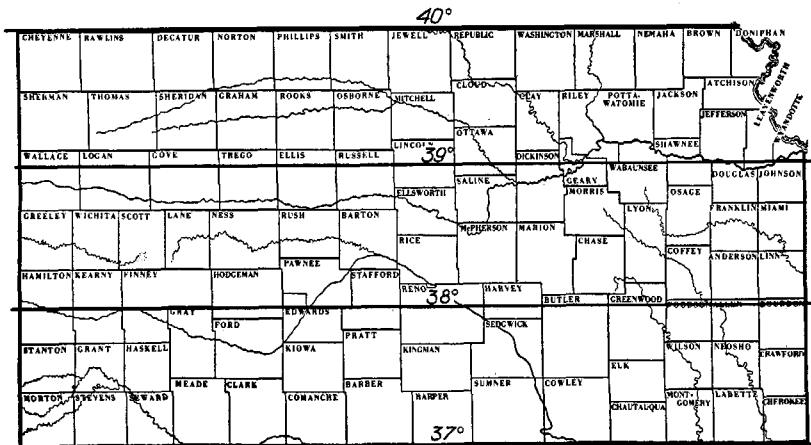

FIG. 32.—Map of Kansas showing latitudes.

**How to Use the Sunshine Table.**—Select the date of farrowing and the nearest latitude to your location. The 39-degree line will be most general for this state. Suppose the back of the pen is 8 feet from the front wall of the house, and the farrowing time is March 1. From the table the height of window for these conditions would be 7 feet, 3 inches above the floor. Locate the window in the front wall with its top 7 feet 3 inches above the floor and the sunlight pattern will fall on the floor just inside the back wall at 10 o'clock in the morning and at 2 o'clock in the afternoon. Between these hours it will travel toward the front of the pen and back again. As the season advances the pattern will move forward across the pen until at noon on July 1 it will fall just inside the front wall.

For pen dimensions not on the table, use the combinations of the figures given. Suppose the pen is 9 feet deep instead of 8 feet. In the column headed 6 feet, the height of windows is given as 5 feet 5 inches. To 5 feet 5 inches add half that amount or 2 feet 8½ inches, which gives 8 feet 1½ inches as the height of top of window for this set of conditions.

The same method may be used for locating roof windows. Locate the point where the top of the window would be if the wall were extended. From this point draw a line to the back of the pen floor, and the point where the line cuts the roof will locate the position for the top edge of the roof window.

APPENDIX

LIST OF AVAILABLE PLANS

Copies of the following plans in blueprint form may be obtained from the Department of Rural Engineering, K. S. C., Manhattan, Kan., at the prices indicated. Order by number.

HOG HOUSES AND EQUIPMENT

**No. 72-621, Hog House.**—22' x 46'. Hollow-tile walls; gable roof with roof windows; concrete floors. Ten farrowing pens; two feed rooms; one mixing room; feed alley between two rows of pens..... \$0.20

**No. 72-622, Individual Hog House.**—"A" shape, 7'-8" x 8'-0". Portable, .10

**No. 72-623, Community Hog House.**—26' x 56'. Hollow-tile walls; gable roof with roof windows; concrete floors; 14 farrowing pens, two feed rooms, one mixing room, 8' central driveway. East-and-west type..... .35

**No. 72-624, Kansas "A"-shape Hog House.**—7' x 7'-8". Unit floor; roof ventilator. Portable ..... .10

**No. 72-631, Hog House.**—12' x 28'. Frame construction; combination roof; concrete floor. Four farrowing pens and feed alley..... .25

**No. 72-632, Individual Hog House.**—7' x 7'-8". Combination type; roof window. Sides open to provide summer shade. Portable..... .10

**No. 72602M, Modified "A"-type Hog House.**—6' x 8'. Unit floor; gable roof; large door in roof; end ventilators..... .15

**No. 72604M, Movable Combination-roof Hog House.**—6' x 8'. Gable roof; rear and front door; air vents in gables; roof door in front. May be equipped with floor..... .15

**No. 72611M, Single-row Farrowing House.**—12' x 42'. Frame construction; roof windows; row of pens and service alley extending full length of building ..... .45

**No. 72613M, Gable-roof Hog House.**—24' x 42'. Masonry or frame construction; gable roof with sunlight windows; concrete floor; 10 farrowing pens, feed-mixing room and feed alley, 2 feed bins..... .45

**No. 72621, Straw-loft Hog House.**—22' x 32'. Frame construction; gable roof; concrete foundation wall carried 4 feet above floor; 7 pens, feed room, 4' service alley, windows in walls and ends..... .30

**No. 680, Hog House.**—20' x 36'. Twelve pens 6' x 8', 6 on either side of 4' feed alley; movable division partitions with hinged fenders; gable roof; concrete foundations; alternate types of pen floors; windows in ends and skylights in roof; sliding doors from each pen to feeding yards..... .15

**No. 758, Hog House.**—20' x 43'. Same as design No. 680, with addition of feed and scales room at one end of building..... .15

**No. 75-12, Portable Fence with Pig Creep.**..... .10

EQUIPMENT FOR SWINE PRODUCTION

**No. 77-612, Feeding Trough.**—Partitioned trough for pigs..... \$0.10

**No. 77-614, Concrete Waterer.**—Underground, frost-resisting, automatic float valve..... .10

**No. 77-616, Barrel Waterer.**—Portable, automatic..... .10

**No. 77-618, Rectangular Feed Trough.**—Shallow trough for pigs.... .10

**No. 77-6110, "V" Trough.**—"V"-shaped trough for hogs..... .10

**No. 77-6112, Double "V" Trough.**—Double "V"-shaped hog trough with partition ..... .10

**No. 77-622, Kansas Feeder.**—Three compartments; total capacity about 50 bushels. Portable..... .10

**No. 77-623, Self-feeder.**—3' x 10'. Three compartments. Total capacity about 60 bushels ..... .10

**No. 77-625, Self-feeder.**—3'-5" x 4'. Two compartments. Total capacity about 8 bushels. Designed for pig clubs..... .10

**No. 77-626, Self-feeder.**—Large size; shed roof; side openings..... .10

**No. 77-627, Self-feeder for Hogs.**—4' x 8'..... .10

**No. 77-642, Feeding Floor.**—Concrete feeding floor, any size in units of 5' x 6' ..... .10

**No. 77-662, Breeding and Ringing Crate.**—Adjustable crate for breeding, ringing, and vaccinating hogs..... .10

**No. 77-664, Castrating Trough.**—Trough for holding pigs while castrating or vaccinating ..... .10

**No. 77-672, Loading Chute.**—Portable chute for hogs, sheep, or calves, .10

**No. 77-682, Shipping Crate for Hogs.**..... .10

**No. 77611M, Hog Self-feeder.**—15" x 3' x 3'. Feed trough on one side only; capacity 5 bushels..... .15

**No. 77612M, Hog Self-feeder.**—2' x 6' x 4'. Two-way feeder with individual troughs and covers; capacity 17 bushels..... .15

**No. 77613M, Hog Self-feeder.**—6' x 16'. Two bins; concrete base, stationary; capacity 650 bushels; height to plate 7 feet..... .15

**No. 77614M, Hog Alfalfa Rack.**—3½' x 8' x 3'. Feeding space for 30 pigs or 16 hogs..... .15